

NO.

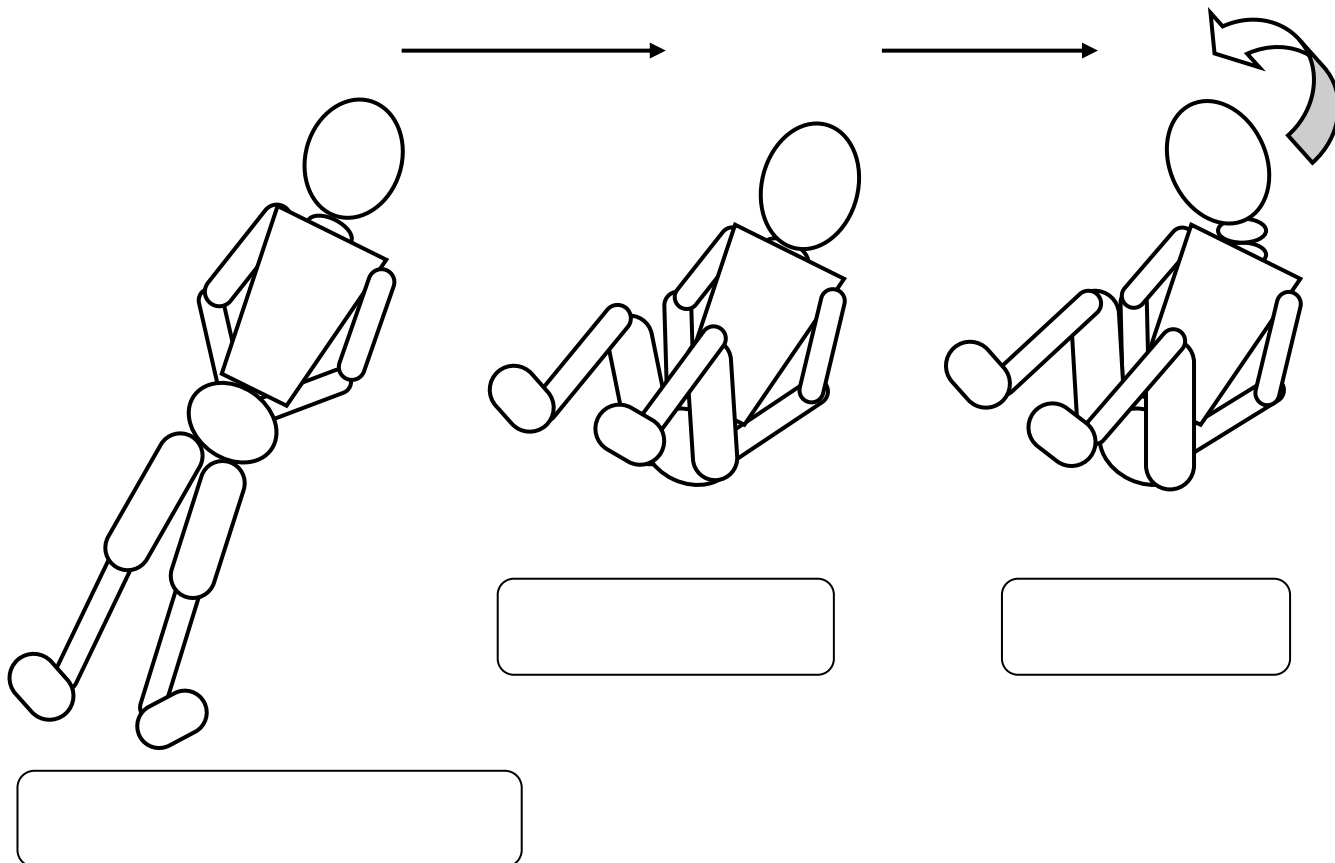

注意事項

NO.

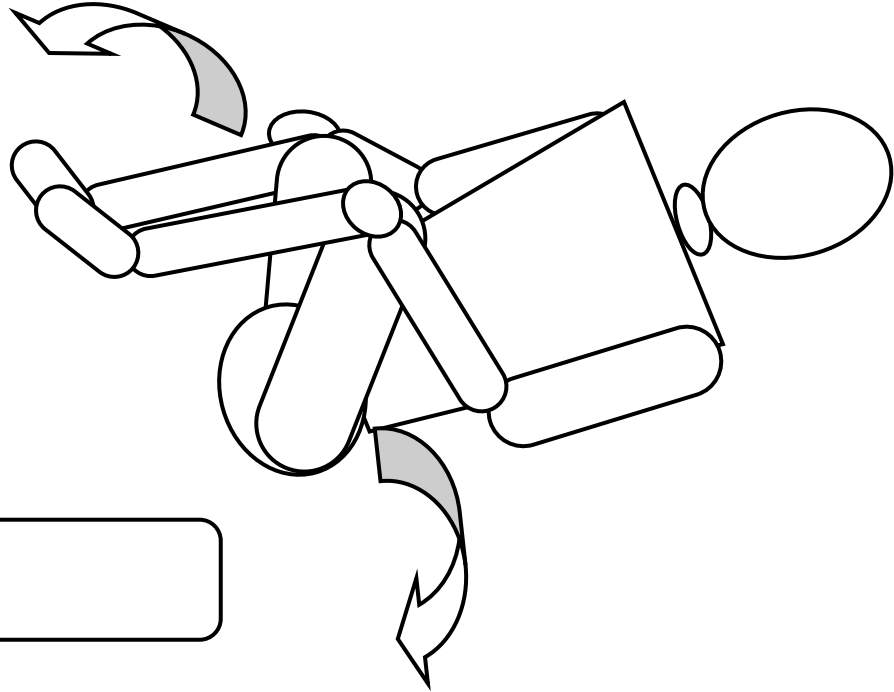

注意事項

NO.

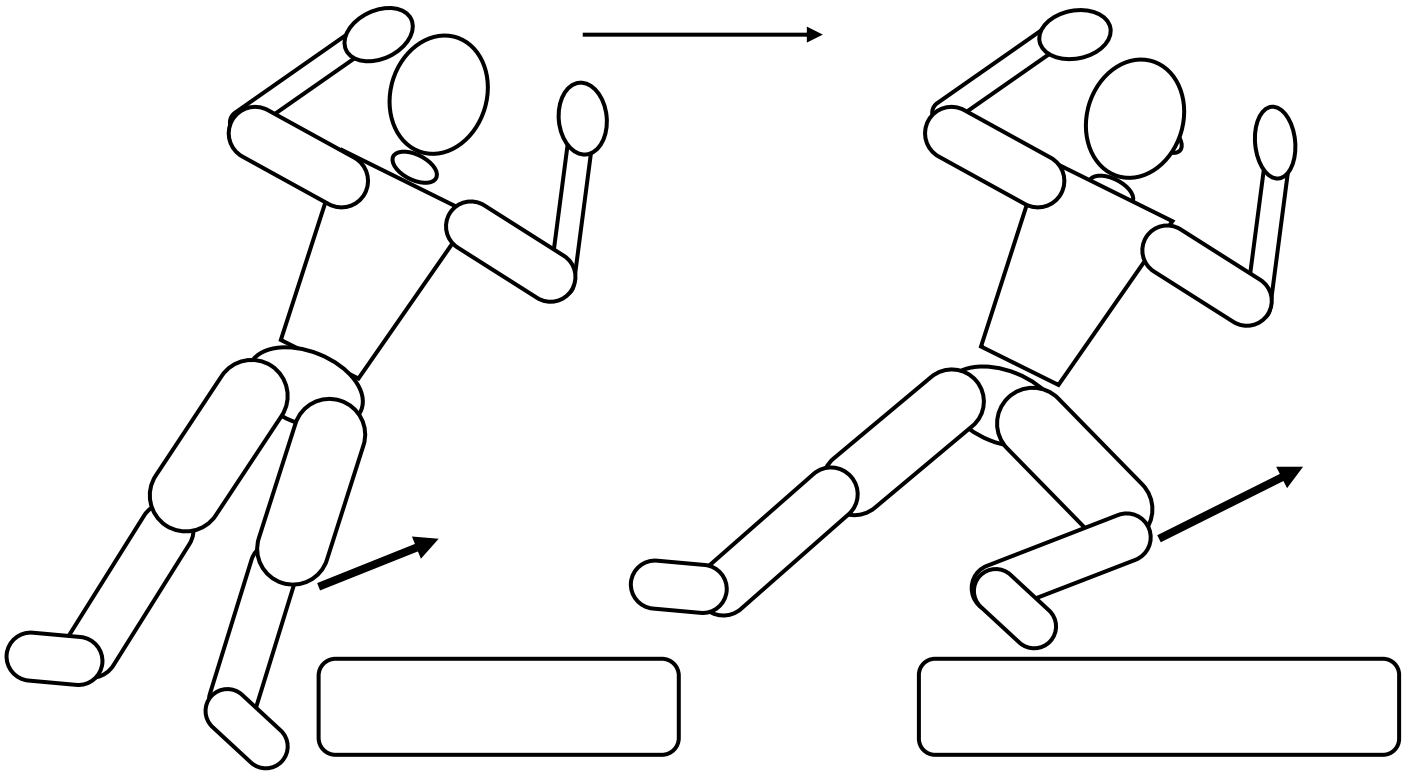

注意事項

NO.

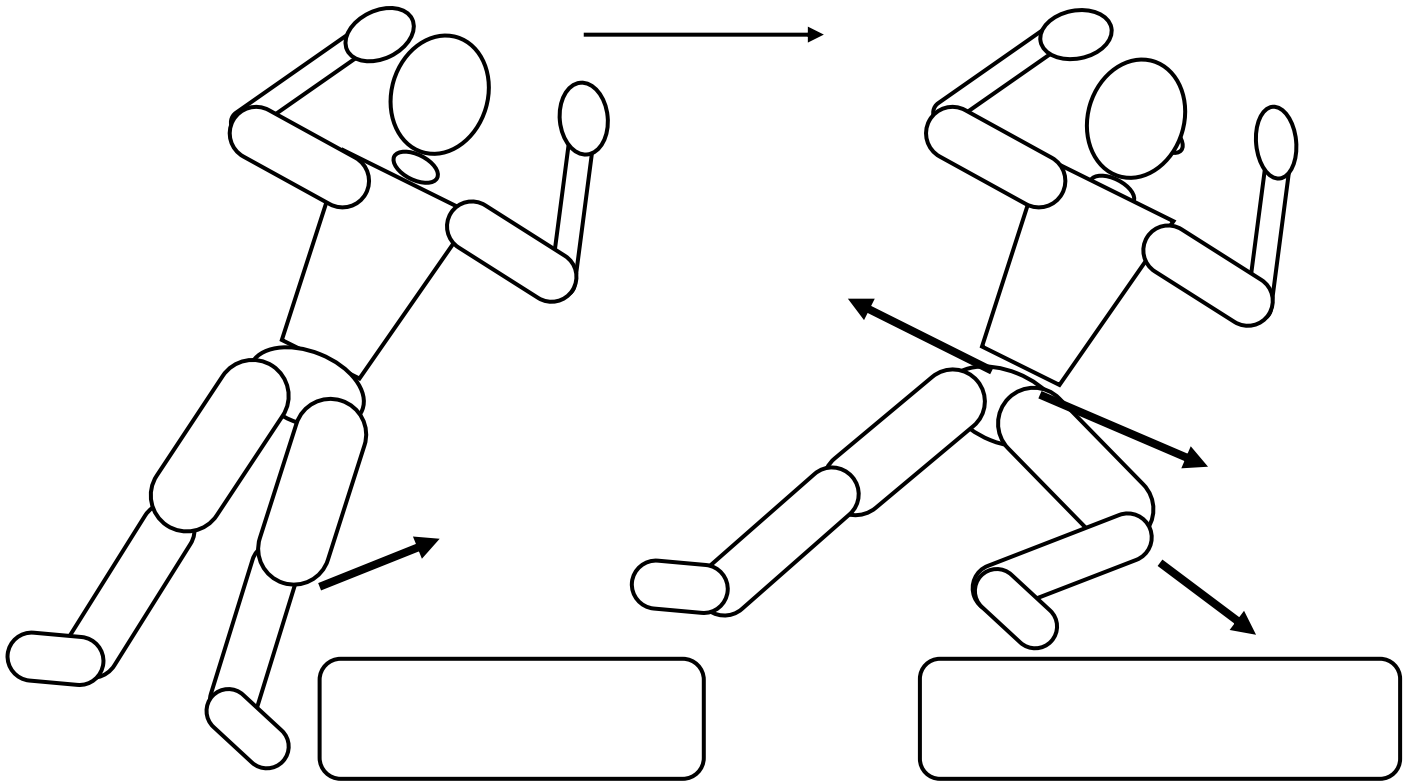

注意事項

NO.

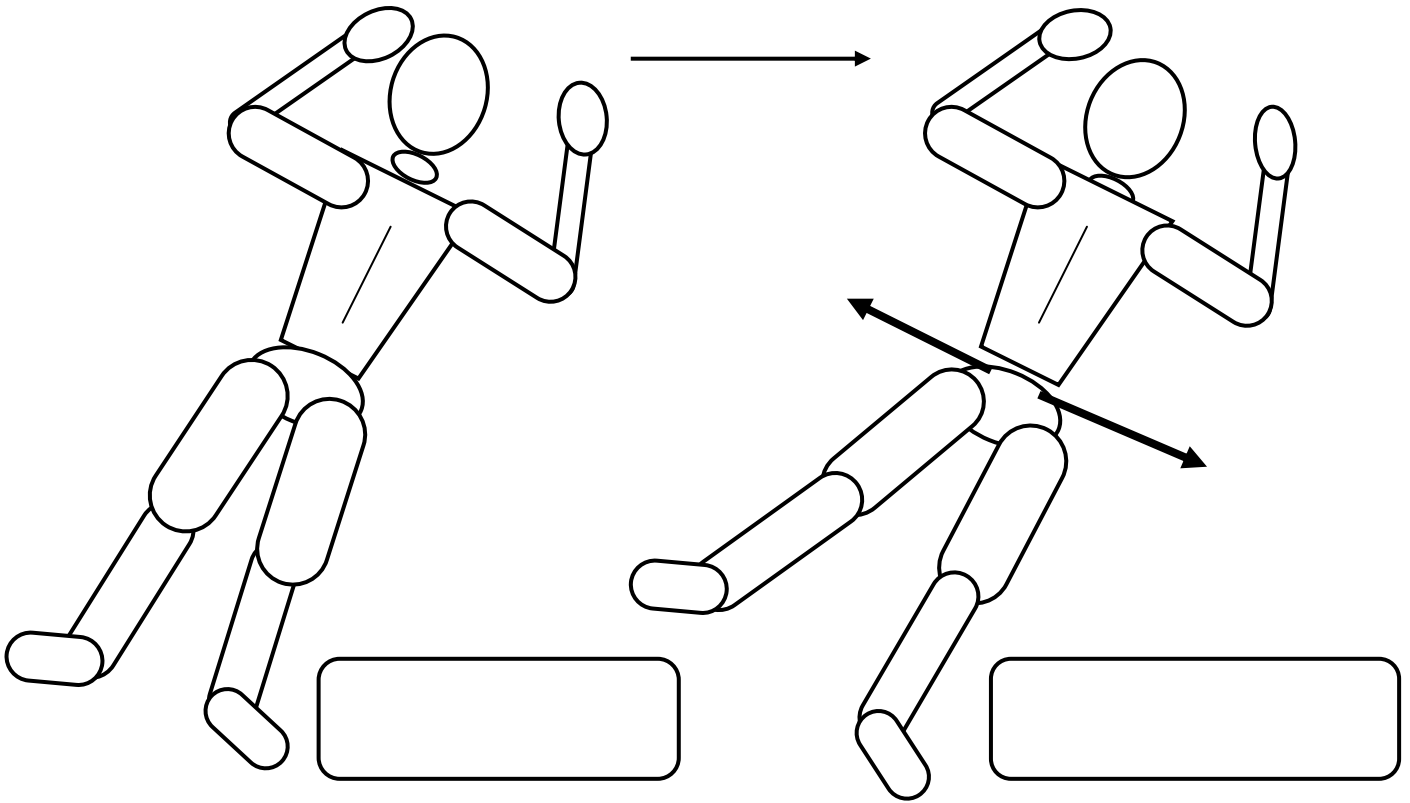

注意事項

NO.

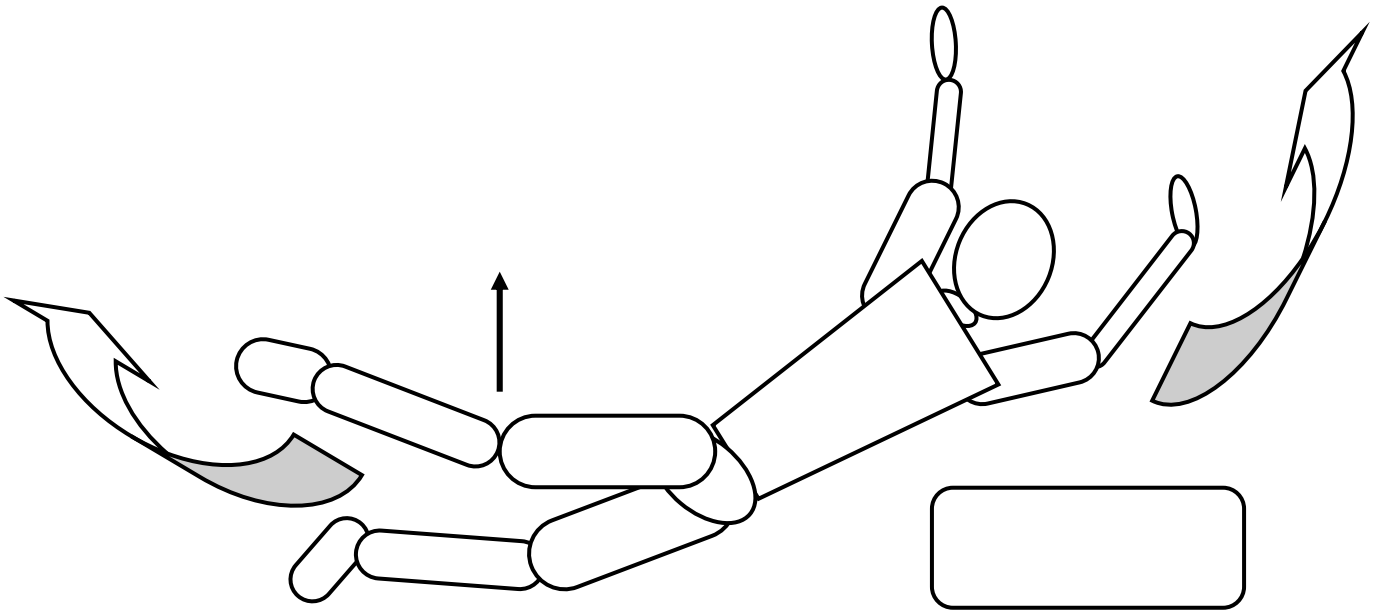

注意事項

NO.

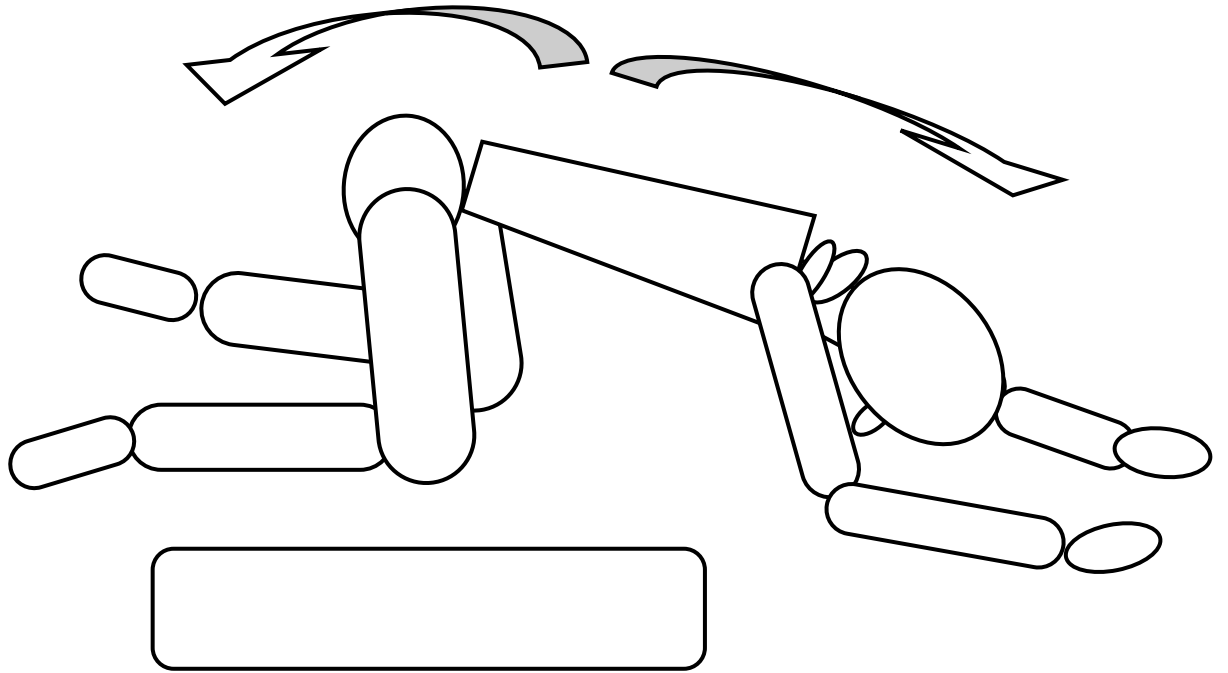

注意事項

NO.

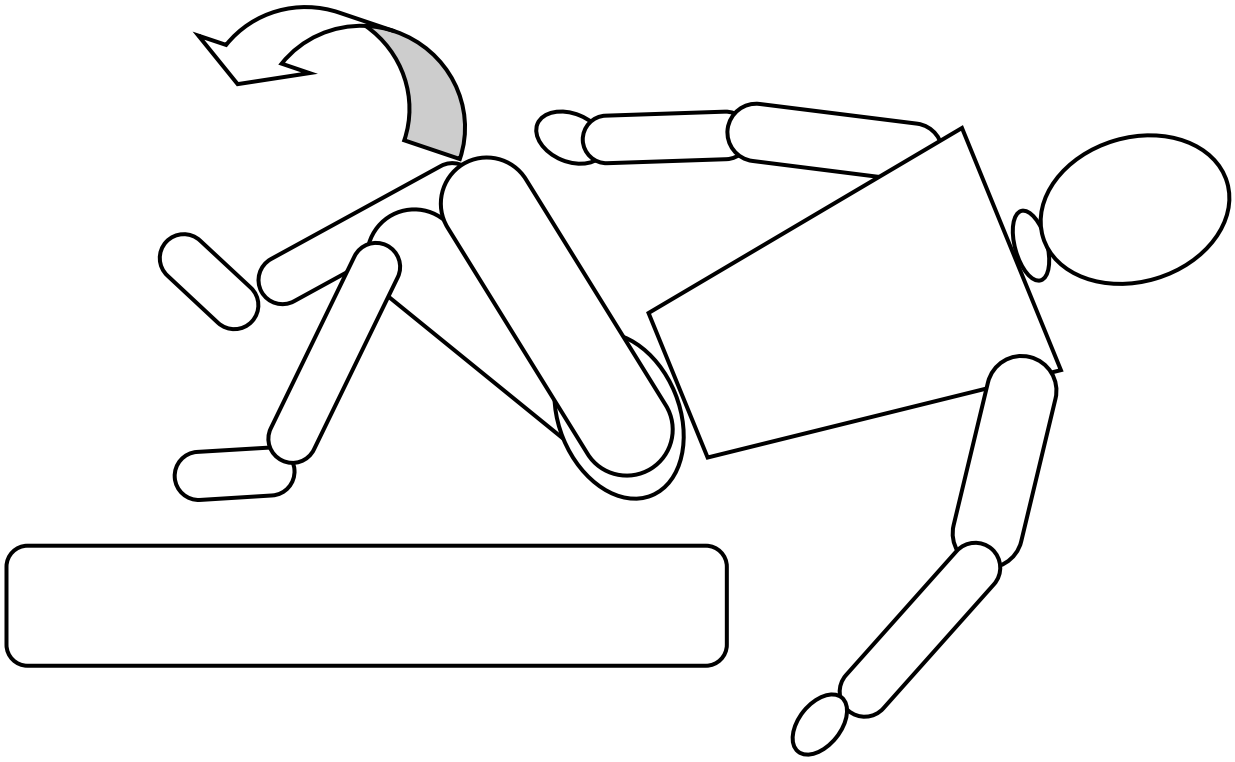

注意事項

NO.

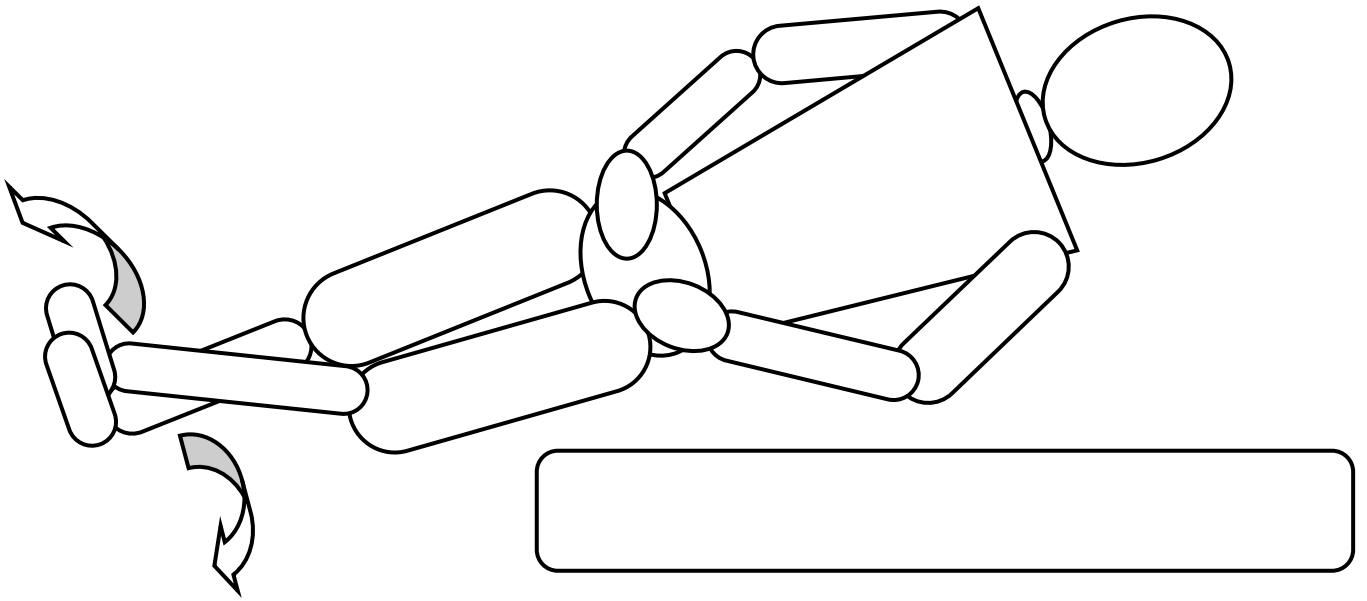

注意事項

NO.

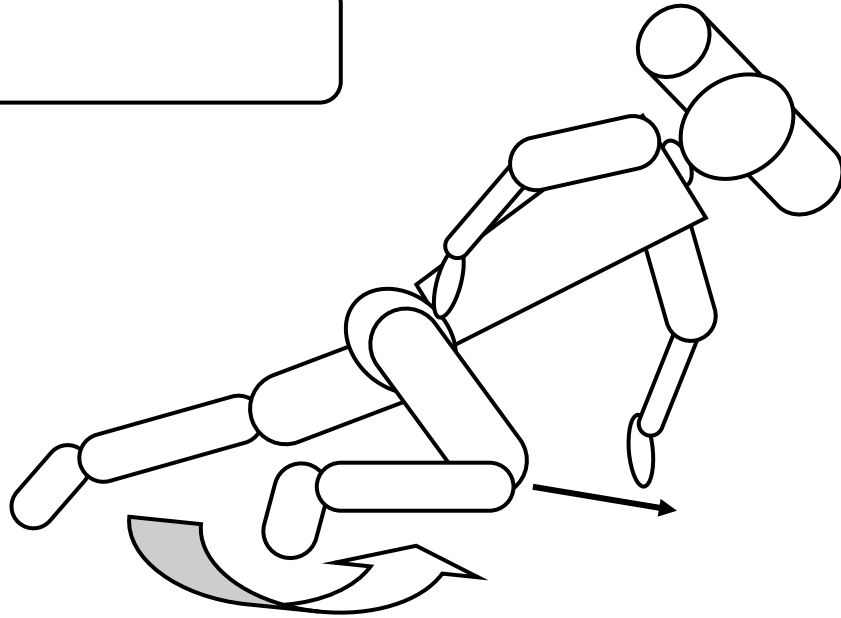

注意事項

NO.

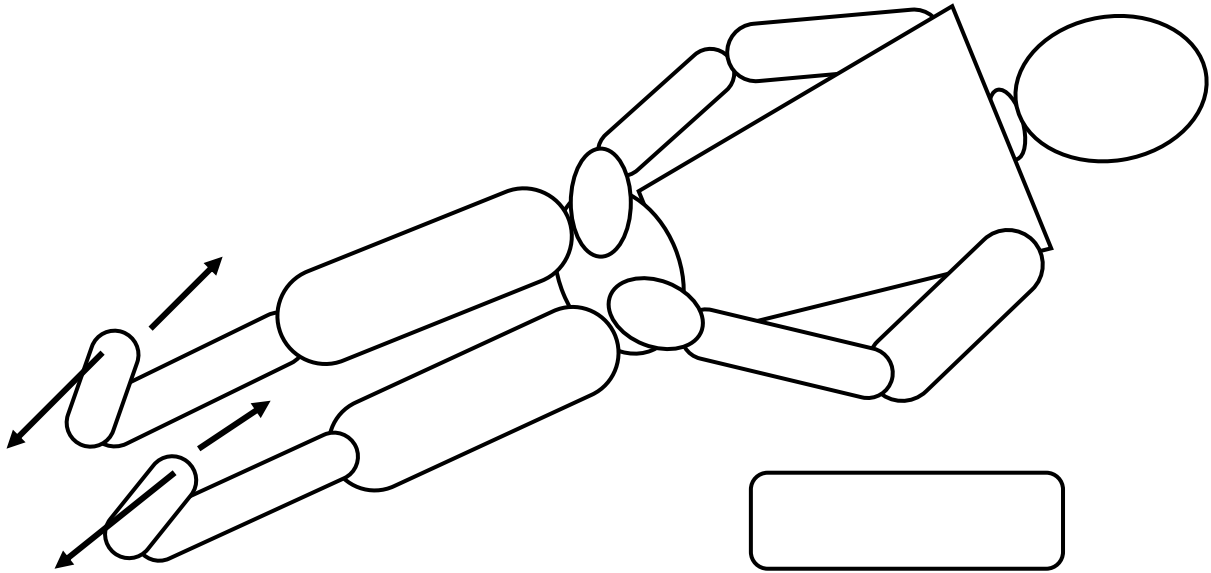

注意事項

NO.

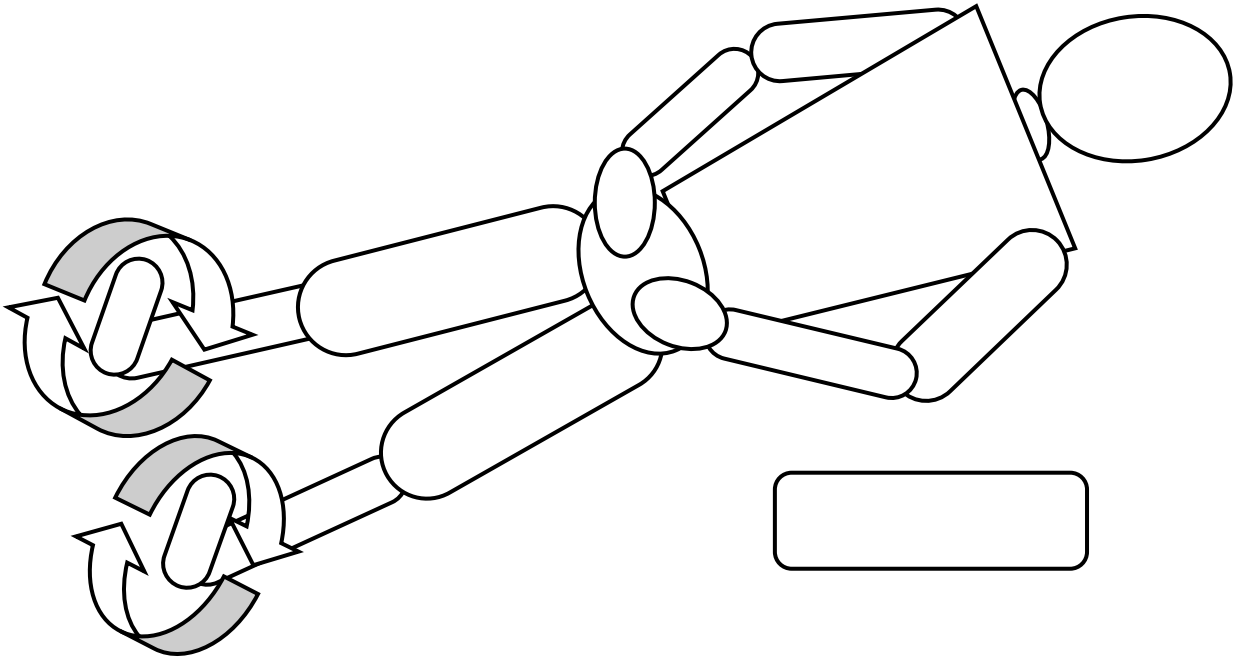

注意事項

NO.

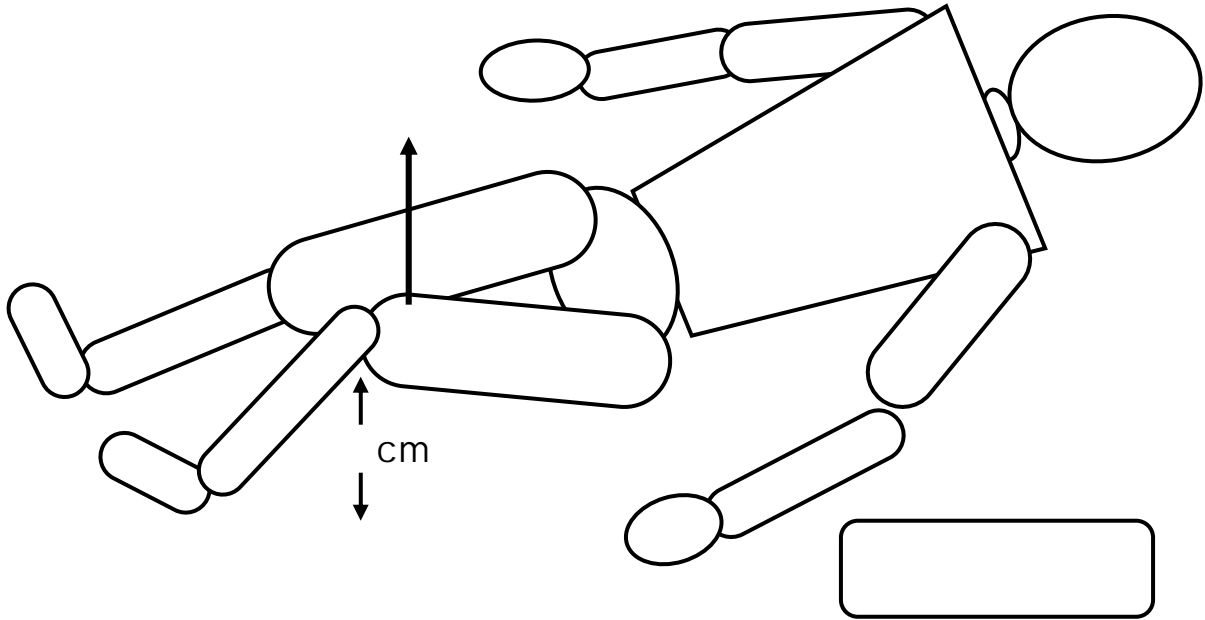

注意事項

NO.

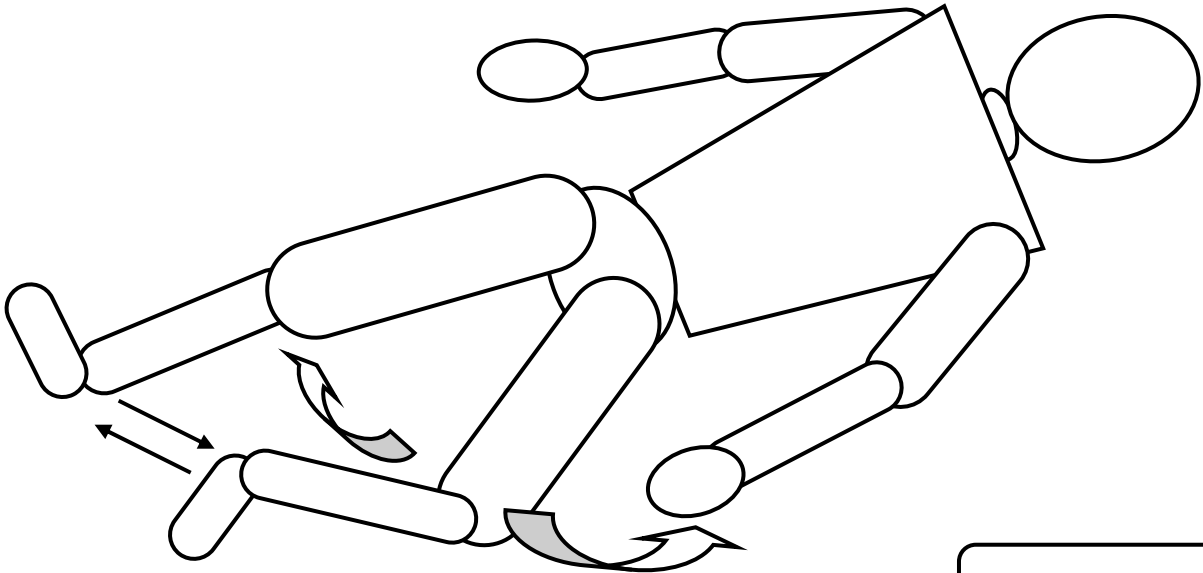

注意事項

NO.

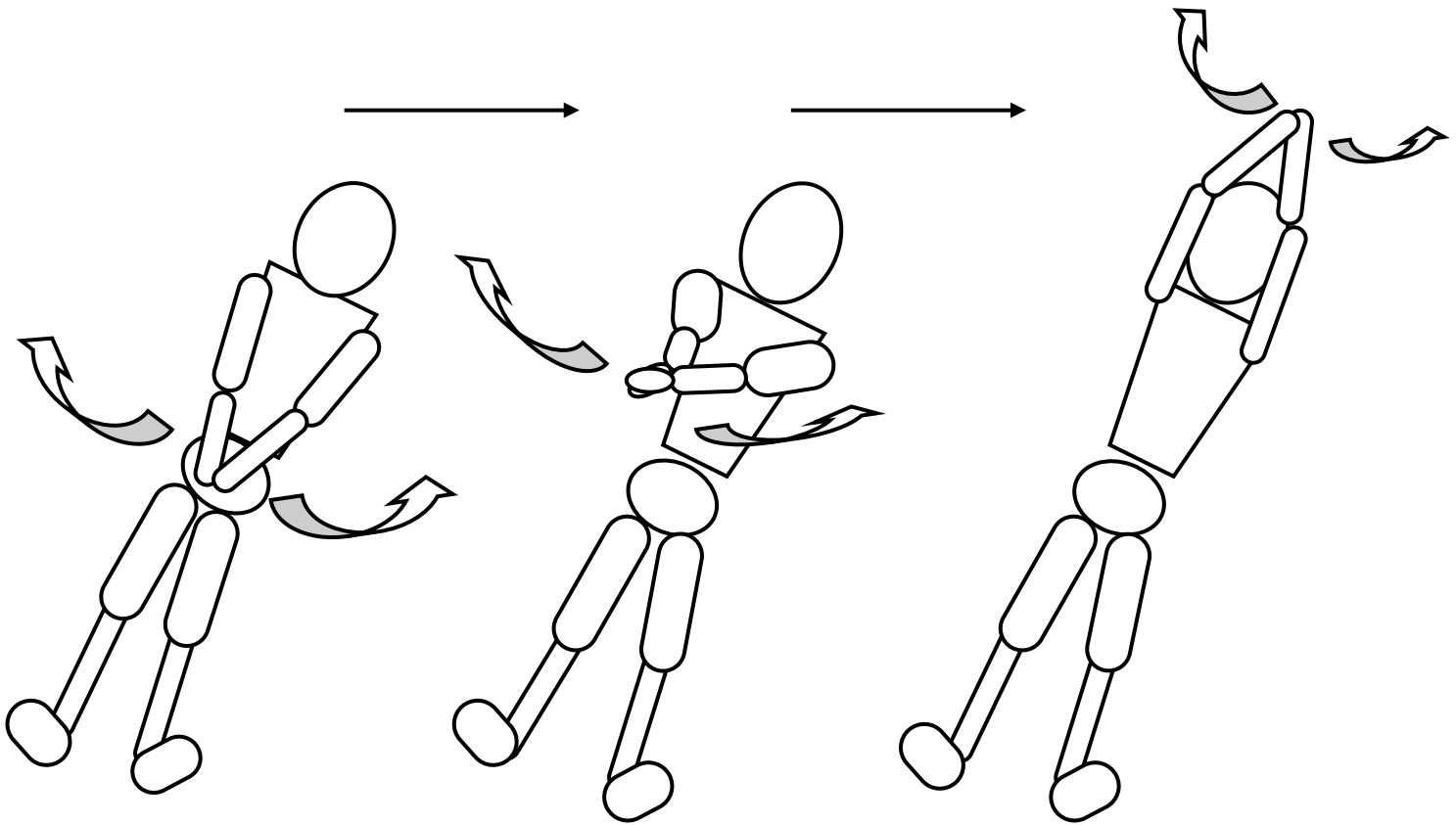

注意事項

NO.

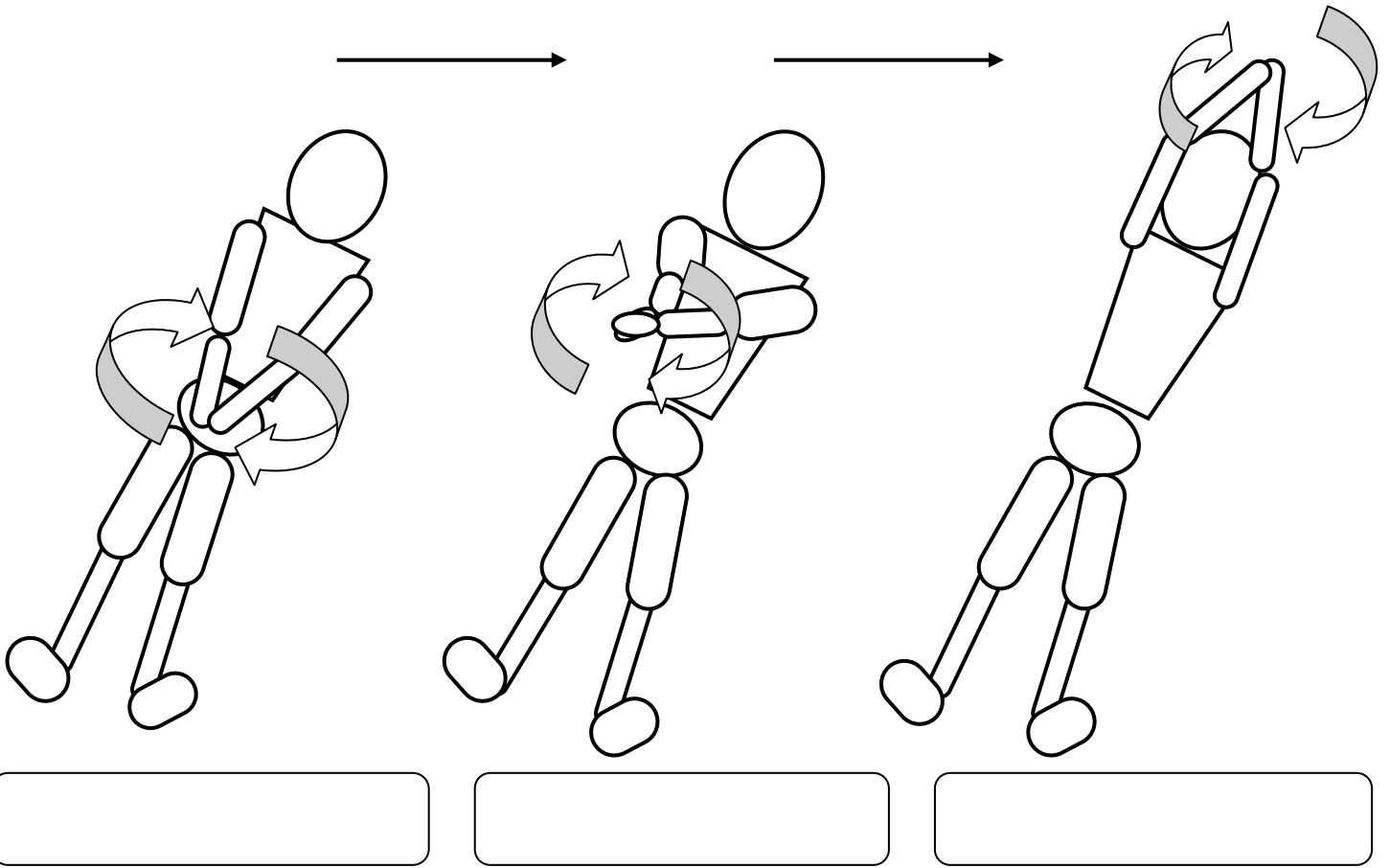

注意事項

NO. _____

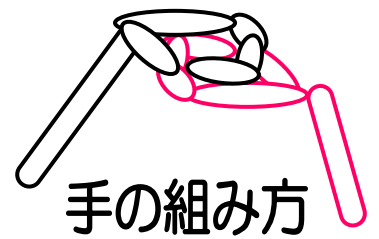
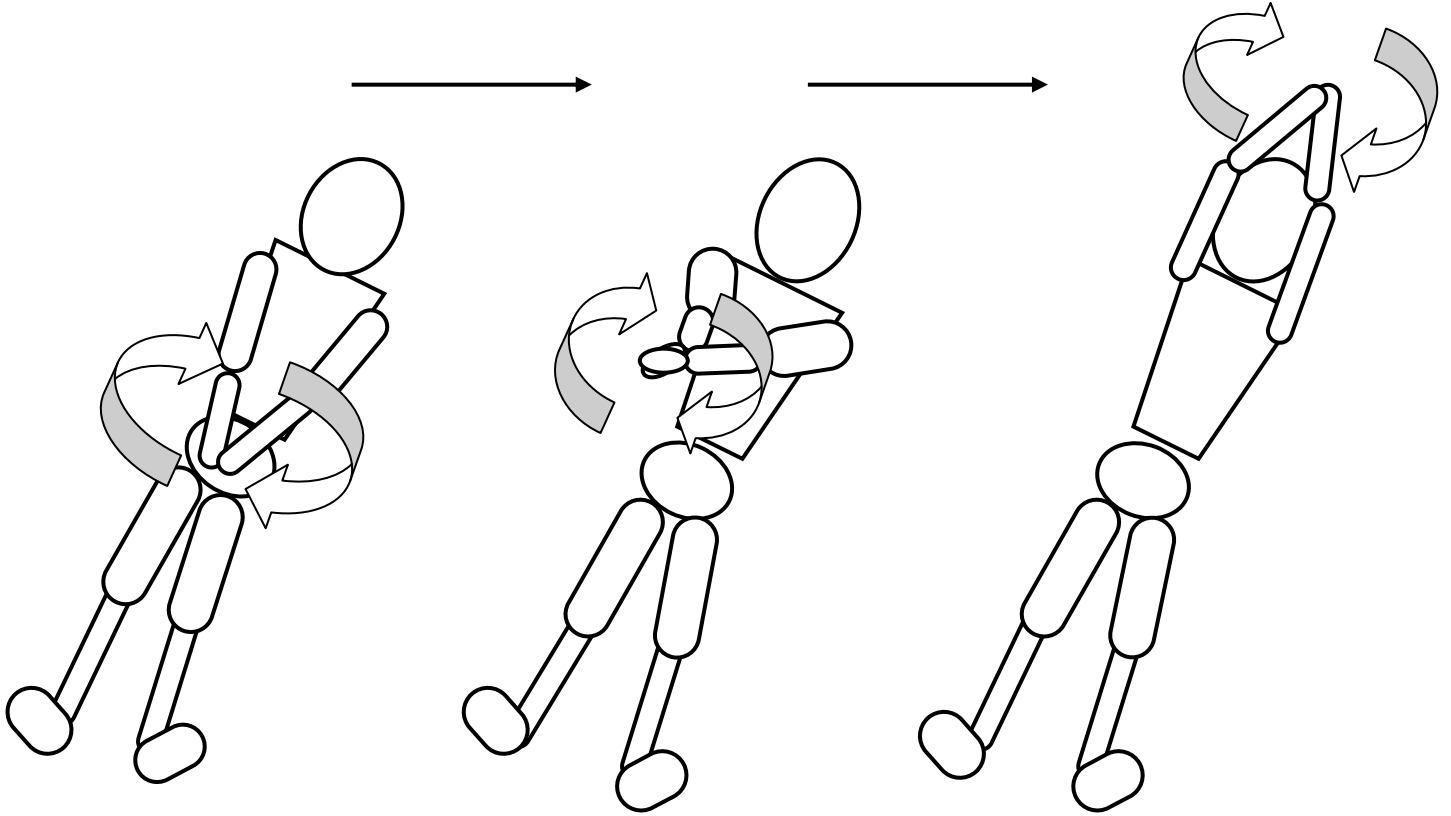

手の組み方

注意事項

NO.

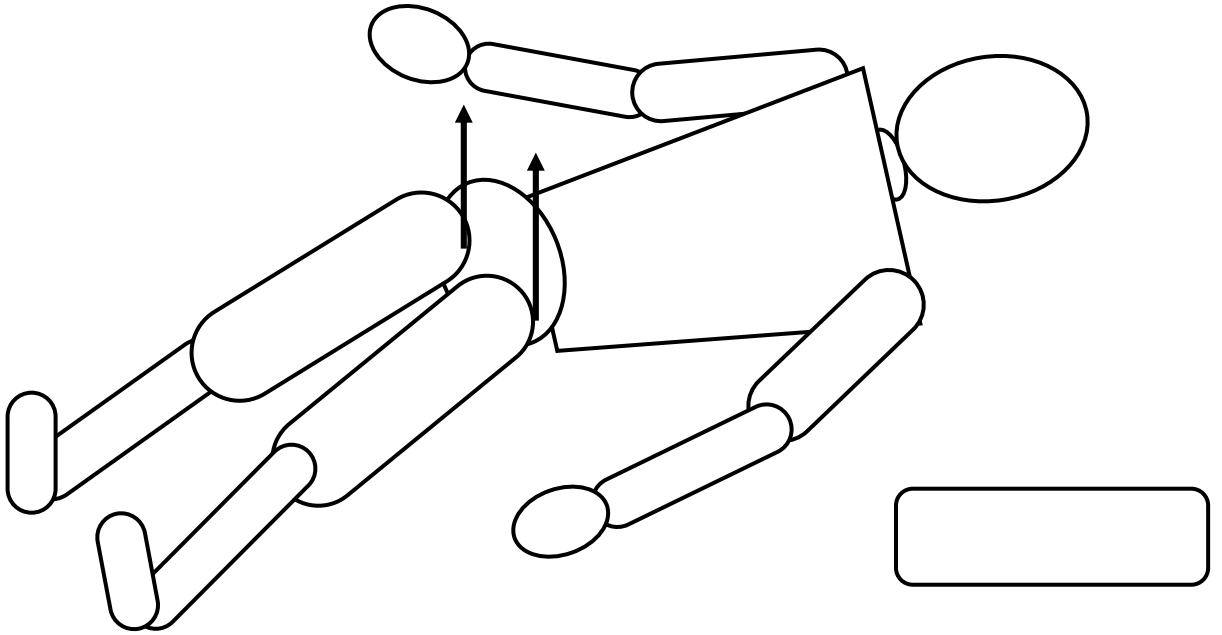

10 15

注意事項

30

NO.

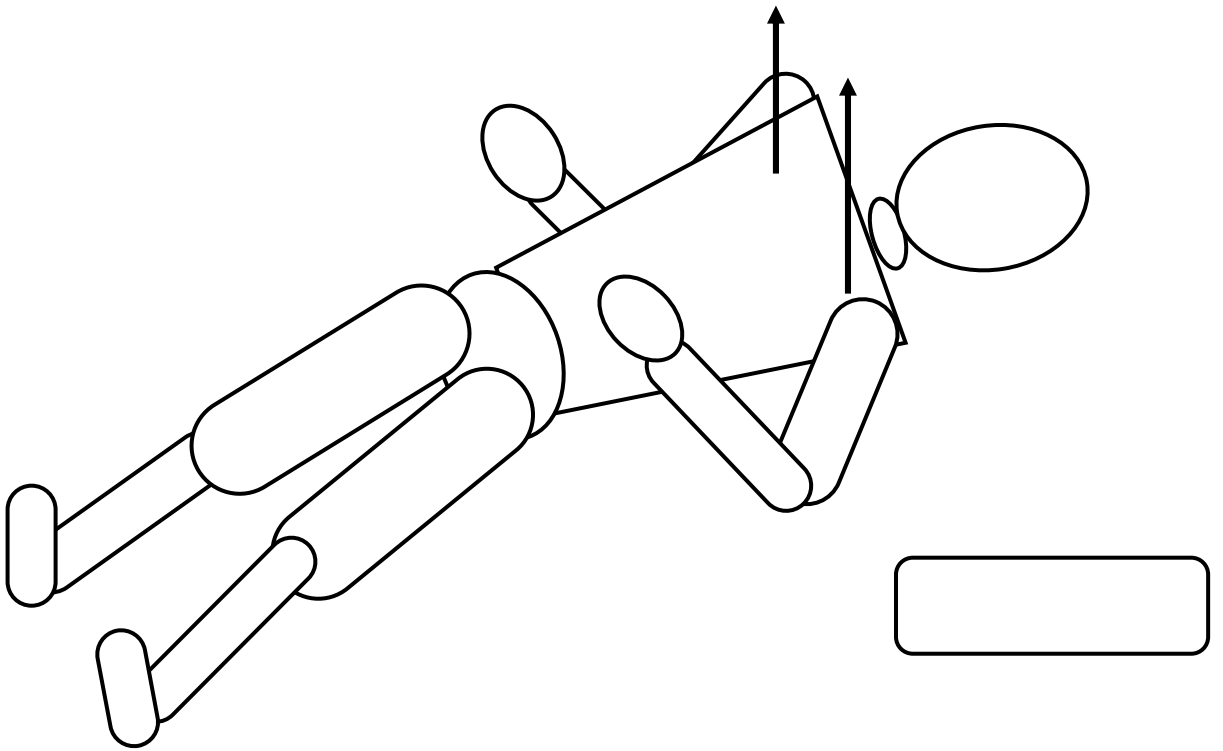

注意事項

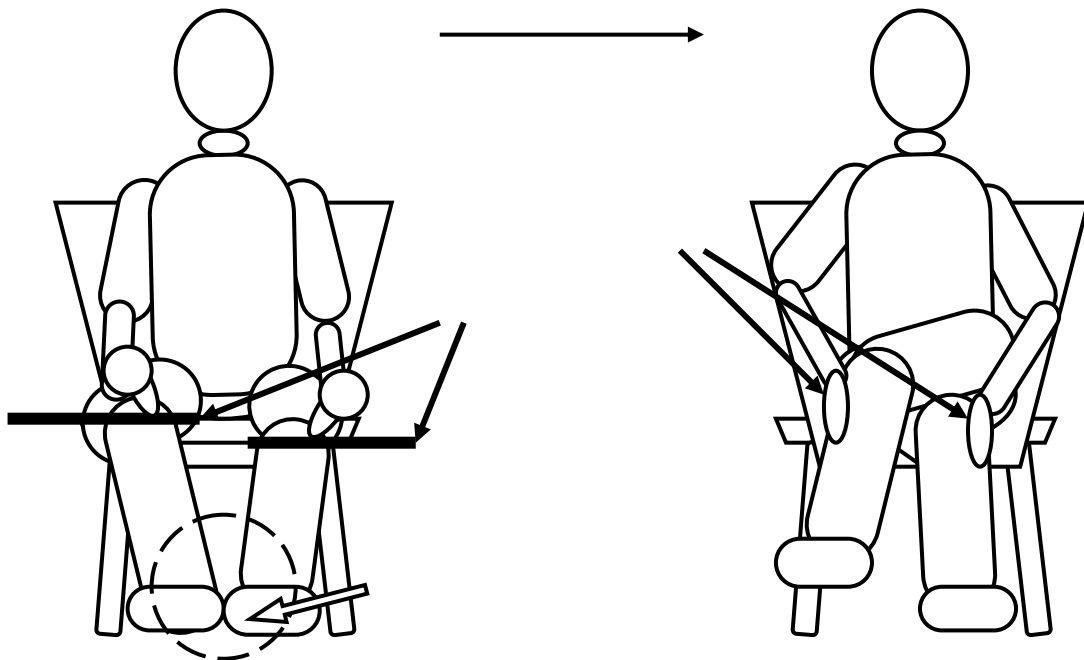

注意事項

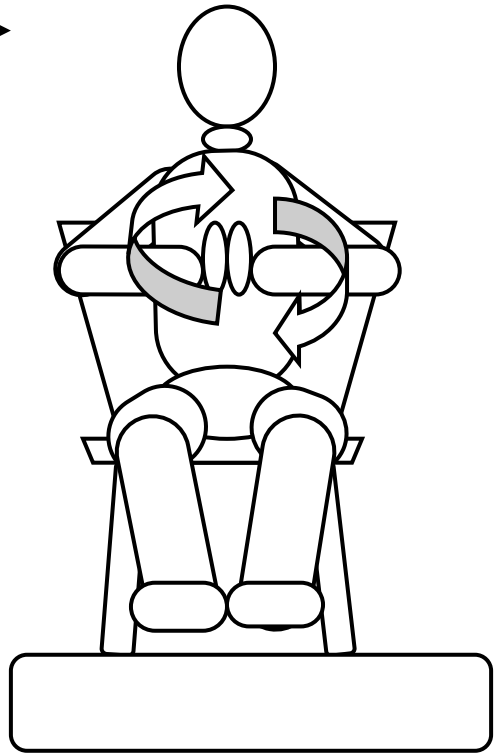
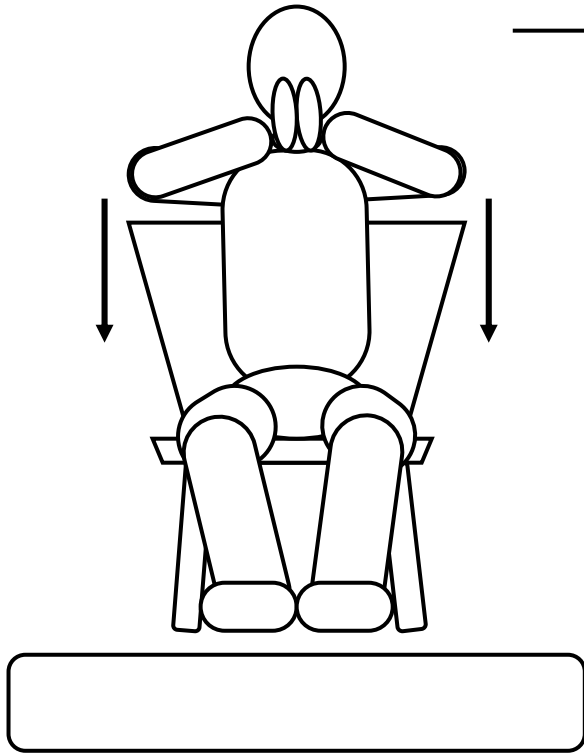

注意事項